

A NOVEL SOFT COMPUTING MODEL ON LANDSLIDE HAZARD ZONE MAPPING

Md. Iqbal Quraishi
Dept. of Information
Technology
Kalyani Govt
Engineering College
Kalyani, Nadia, India

Goutam Das
Dept. of Information
Technology
Kalyani Govt
Engineering College
Kalyani, Nadia, India

J Pal Choudhury
Dept. of Information
Technology
Kalyani Govt
Engineering College
Kalyani, Nadia, India

Mallika De
Dept. of Engg and Tech
Studies
University of Kalyani
Kalyani, Nadia,
India

Abstract — The effect of landslide is very prominent in India as well as world over. In India North-East region and all the areas beneath the Himalayan range is prone to landslide. As state wise Utrakhand, Himachal Pradesh and northern part of West Bengal are identified as a risk zone for landslide. In West Bengal, Darjeeling area is identified as our focus zone. There are several types of landslides depending upon various conditions. Most contributing factor of landslide is Earthquakes. Both field and the GIS data are very versatile and large in amount. Creating a proper data warehouse includes both Remote and field studies. Our proposed soft computing model merge the field and remote sensing data and create an optimized landslide susceptible map of the zone and also provide a broad risk assessment. It takes into account census and economic survey data as an input to calculate and predict the probable number of damaged houses, roads, other amenities including the effect on GDP. The model is highly customizable and tends to provide situation specific results. A fuzzy logic based approach has been considered to partially implement the model in terms of different parameter data sets to show the effectiveness of the proposed model.

Keywords- *Landslide, Earthquake, Image Processing, Fuzzy Logic, Himalaya, Darjeeling, GDP, Risk, Remote sensing, PGA*

INTRODUCTION

Studies regarding landslides are not a new field of exploration. All the countries more or less are affected by this natural disaster so it causes most of them to be involved in this field. Movement of ground or land mass within an instance of causes loss of human life, property, agriculture. Within a very short period of time the casualties grows significantly. When landslides occur, they can move quickly downslope at rates of several m/s, or they can creep slowly at rates of only a few mm/year. On the one hand, they can move instantaneously following a specific trigger such as an earthquake, an intense rainfall, may show a delayed response to critical triggering conditions. In long term consequences the overall growth of the area gets affected. Reimbursement is costly and it takes time to overcome the losses caused by landslide. South-East Asia especially in India studies on landslides is taken place from early 80's [GSI website]. North-eastern and Eastern Himalayan region in India are verily affected by landslides from time to time. India is reported to have

23% total loss of life due to landslides [14]. As population is an area of concerns it also adds up into the landslide problem. As population is increasing rapidly, searching for new residential location is getting explored without the concern that how safe that place is or may be. Geological Survey of India is involved in landslide hazard zonation mapping. The area of Earthquake Induced Landslides (EIL) is identified as the most neglected area of research. EIL is crucial in all aspect. The amount of affected people in EIL is greater than any other cause of land slide. Disaster management which is becoming India's priority R&D field includes landslides as a dominant disaster area to be addressed. Landslide is never caused by a single reason; involvement of different types of parameters makes it difficult to gauge that which parameters are actually involved. Earthquake and rainfall are the two prime reasons. But factors such as slope angle, soil, pressure of a construction etc. are not prominent but must be taken into account. Tsunami induced landslides are also prominent. On hilly area earthquake and rainfall is vital. On coastal are tsunami is considered. A detailed list of parameters may look like this, slope, aspect, curvature, soil texture, soil drainage, soil effective thickness, timber age, timber diameter, distance from drainage, distance from roads, distance from faults, distance from lineaments, parallelism between the fractures, landslide scarps, lithology, geological structure of foliation, geomorphology, normalized difference vegetation index (NDVI) and land use. Coarse soil types are more susceptible to landslides; bare soil contributes more to landslides. Light soils like sandy or coarse loams are easy to detach as they have low organic matter content (Das and Agarwal, 2002). soil with more sand, high slope and intensive rainfall which constitute most dominant factors of landslide cause severe damage to land (Patanakanog, 2001) .Soil is characterized by either severe erosion, moderate erosion or low erosion. Soils with more stones (or rocks) are less prone to the landslide as compared to that of soil with less stones. If the percent of slope is increased four times, the velocity of water flowing down is doubled [21]. Doubling the velocity of erosive power in hills during monsoon season, the hills get saturated with water, resulting in instability of land mass. Higher the level of hydraulic

conductivity of soil, higher is the probability of the landslide. The study area is to be classified into high, moderate and low hydraulic conductivity.

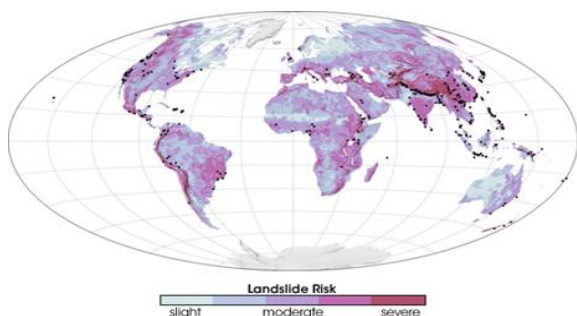

A map by NASA showing landslide risk zones worldwide.

State Inter Agency Group, West Bengal, in their website published the data of casualties of last 27 years. Death because of landslide is more than 155, houses damaged are more than 2 corers, and population effected is more than 3 lakhs. The severity of the landslide alone in Darjeeling cannot be overlooked. The condition in pan India is worse. The absence of a proper model can be realized, due to this huge number of casualties. Landslides have represented 4.89% of the total natural disasters that occurred worldwide during the years 1990 - 2005 (www.em-dat.net) [1].

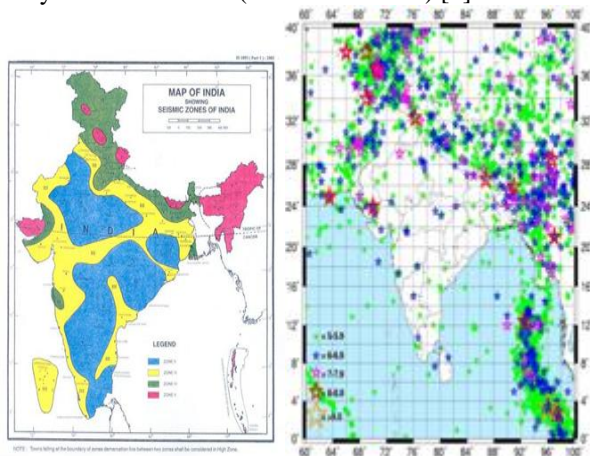

A. Different soft computing approaches:

In order to cope with a large number of the developmental projects for communication, highways, dams, reservoirs etc. a risk free sustainable environment is needed. A study using ANN for landslide susceptibility map [3] shows that if more parameters are added to the complex problems of landslides the results will be encouraging. A research proposal for knowledge based analysis of landslides in Darjeeling zone shows us a predictive model [4] for landslide. ANN is able to solve nonlinear problems just as well human brain**. Landslide characteristics, depending upon various parameters makes it nonlinear, so ANN is a good help. Neural network based results are better than GIS based LSZ mapping [11]. The effectiveness and reliability of GA based ANN (GLANN) for Landslide Hazard'

Zonation Map [12], depending on several parameters, produces good results and it is supposed to focus on landslide mitigation measures.

Spatial distribution of landslides to create an accurate susceptibility map [5] can be more refined to get more localized results. However it is found that models those works with small areas most of the time fail to produce results for larger areas [Sekhar et al. 2009]. For spatial data analyzing the importance of GIS increased many folds [6], though the study does not include earthquake and rainfall data but still the model produces thematic layers which is then allotted with numerical values of the factors. But it is found that GIS alone cannot answer the entire question. A GIS based rating system can be helpful to produce thematic rating of layers [7]. A macro zonation map is preferable for realistic approach. GIS based hazard maps produced preferably at a scale of 1:10,000 or 1:25,000 is preferable in this case [8]. Each map layer can be considered as a separate layer features in a map, with a rank associated, which will help us to predict susceptibility of landslide [9]. The use of GIS tools such as ArcGIS Spatial Analyst and Arc-SDM for statistical integration has improved the results of studies[10]{how}. The combination of GIS based data with data mining techniques to recognize patterns from large data sets for effective decision making by building decision trees, makes a complete data driven and knowledge based Landslide Susceptibility and Hazard model [15].

Fuzzy logic, it is extended which is meant for finding partial truth values between completely false and completely true region, unlike Boolean results which produces true and false only, degree to which a member belongs to a set is expressed by the membership function. Kundhapallam Watershed, Nilgiris, fuzzy theory is been tested in combination with GIS data to narrow down the susceptible zones. It is used to find membership values for each thematic layer [13]. A 2 level fuzzy combination is supposed to produce practical results [16] with still room for improvement. Factor analysis after fuzzification of each parameter [17]; generate a high success rate in landslide susceptibility mapping.

Statistics regarding Gross Domestic Product (GDP) of a country is like a total average picture of the country's development and growth. A country like India which has the potential to sustain a good GDP can be affected by seismic activities and it's after effect as landslides. A study shows that expected losses are high in states like Uttar Pradesh, Haryana, Bihar, West Bengal, and Assam [18]. It also proposes a model where earthquake related GDP losses can be estimated by using several accrued databases. Which is by far can be helpful in the study of earthquake related landslides. As rainfall is considered as a prominent factor causing landslides, survey of rainfall with damage analysis of ambootia, an area of Darjeeling Himalayan range shows that rainfall over 50 mm reached 24–26 per year [19]. It also

conclude that ambootia like conditions exists at many part of Darjeeling Himalayan area, which indicates that the zone is not safe from upcoming landslide hazards. Due to the advent of satellite images, the landslide monitoring became more efficient in the sense that it provides monitoring for real-time. Development of image processing arena is helpful for analyzing these real-time or recent type images. In a case study in japan showing, how principal component analysis can effectively detects landslides having accuracy of 88% to 90% [20]. This study involves software's such as Erdas imagine version 8.7, ArcView version 3.3 and ArcInfo version 7.2.1.pre processing of images like, extraction and filtering. It is necessary as these types of images contain high amount of redundant data and differ rent type noises due to atmospheric conditions.

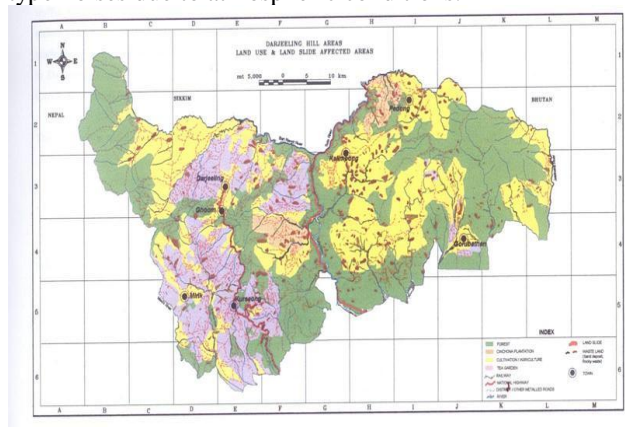

Map of land use in Darjeeling

B. Proposed soft computing model:

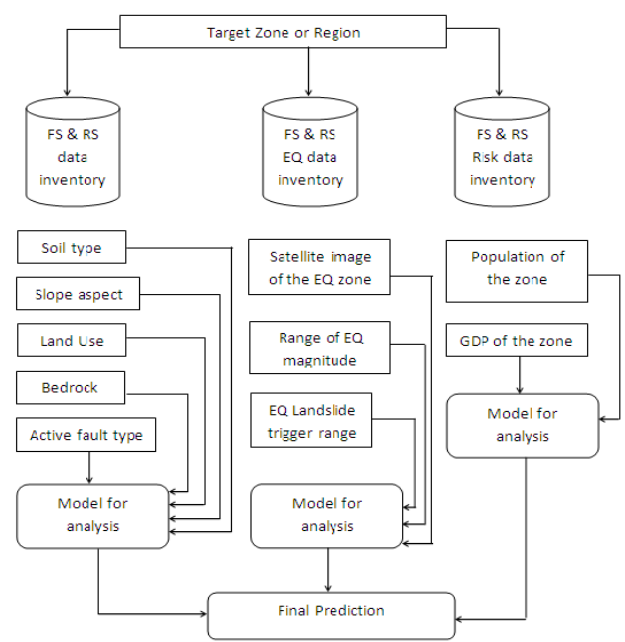

Note: all data need to be normalized before use.

C. Analysis of the proposed model:

The central part of our proposed model is based on earthquake. Initially the model comprises 17 parameters. Logically we can divide the whole model in two halves. First the landslide susceptibility and second one is risk analysis. Risk analysis involves number of human life in susceptible zone, GDP of that zone, number of roads and houses that can be affected. Data for population and houses can be gathered from census reports of the zone. We can also find the data regarding increase in civilization. Number of roads can be found by the state transportation and state highway authority and national highway authority. Satellite images for 20 years can also be used to see the change in population, roads, and houses. Data regarding GDP can be gathered from state and central economics departments and institutions. Without the GDP data it will not be possible to explore how landslides affect the economy of a certain landslide susceptible zone. Houses roads and GDP together can generate a whole some picture of landslide effects on population. A step wise discussion on various parameters and there probable necessity including approaches that can flow with this model are detailed below.

Step1: Create a landslide data inventory using both field study and remote sensing data.

This is the basic step to implement first as there may be hundreds of landslides cases in the zone it is necessary to collect those data as required by the parameters.

- a) *Type of soils:* all the soil types that was found in the previous landslides of the study zone.
- b) *Land Use:* the model requires land use data to be provided to check whether any part of the area of the study zone is used in agricultural purpose or not.
- c) *Bedrock:* the type of bedrock found in the landslide zones and types of bedrocks involved in previous landslides.
- d) *Number of active faults:* faults are necessary input parameter. As it is found that contribution of active faults are vital when earthquake based landslides occurs. If an earthquake occurs in the fault zone its effects increases many folds.
- e) *Slope angel:* calculating slope angels are necessary because the amount of land mass that can flow downwards depends upon it.
- f) *Satellite images of the EQ zone:* satellite images of the zone to identify and monitor the earthquake probability and previous earthquake hazard.
- g) *Landslide triggering range of EQ magnitudes:* this data set should be created depending upon previously recorded landslides due to a certain range of EQ magnitudes.

- h) *Population*: number of houses, total length of road of the landslide zone and population count. This data set will help us counting the probable number of casualties of human life. Also it will help the model provide a broad view of risk calculation.
- i) *GDP*: It will map the socio economic scenario of the zone. Economic data of the zone to be calculated by the GDP data and per capita income of the house hold.

Step2: Input into the model for analysis:

The proposed model is based on four column architecture. Classified data has been put into different columns for analysis purpose. For evaluation purpose all the models for analysis are based on fuzzy logic. In some cases artificial neural network can be used in combination with fuzzy logic for clustering and classification purpose. It generally speeds up the process of fuzzy logic by training data set generation which in turn helps to produce fuzzy rule base efficiently [22]. In this present work the whole concept is in general, based on fuzzification of the data for analysis and fuzzy rule base for final outcome is been considered.

D. Fuzzy logic based approach:

Following the If-Then-Else rule base, fuzzy logic represents a more human way of thinking which includes uncertainty among choices and decision making. It was first proposed by Lotfi A. Zadeh (Zadeh, 1978) in the year of 1965. Fuzzy logic inherits fuzzy set theory in which entities can belong to several subsets. The concept of fuzzy logic starts with fuzzification of the data set followed by defining a membership function like Gaussian; trapezoidal etc. with value a numerical value associated with each of it. Next the inference, which is nothing but the application of the rule base to produce fuzzy membership value as result. In our proposed model, for evaluation purpose a pure fuzzy logic based approach has been considered. Slope angel, lithology, fault type, bedrock type has been taken into consideration as a crisp number for membership function, which eventually, considering the rule base, produces ratings of the landslide hazard zone.

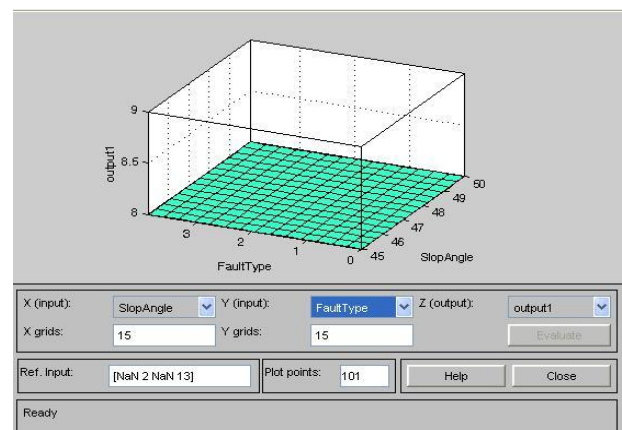
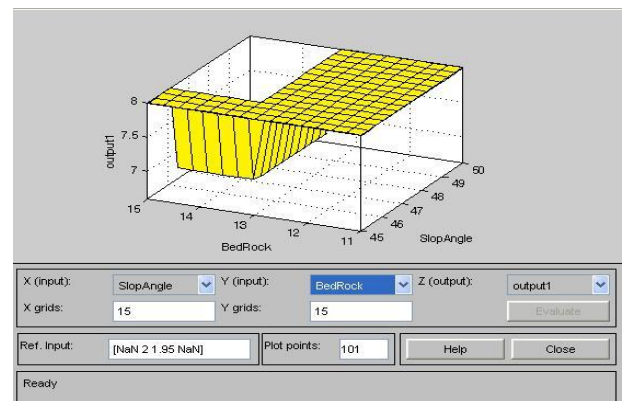
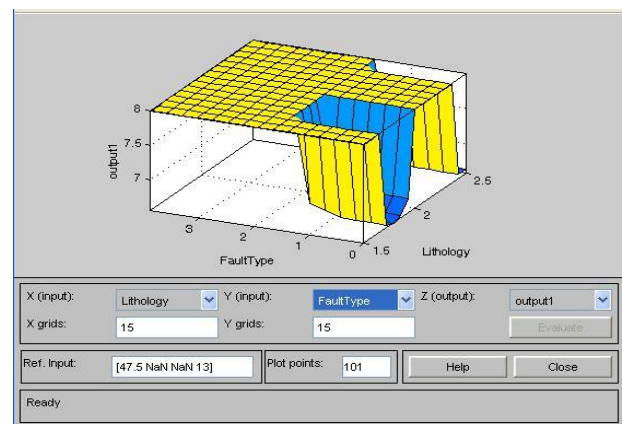
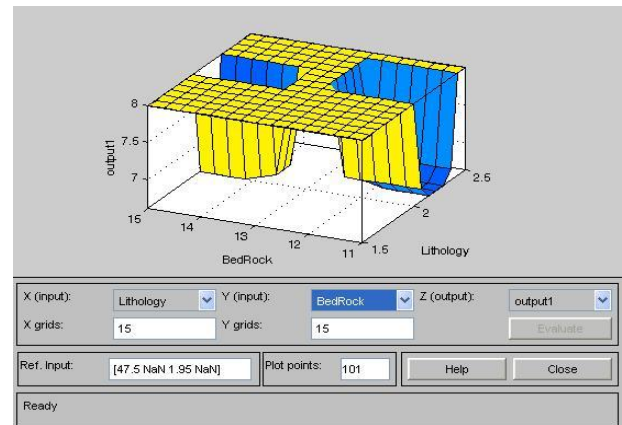

RESULTS

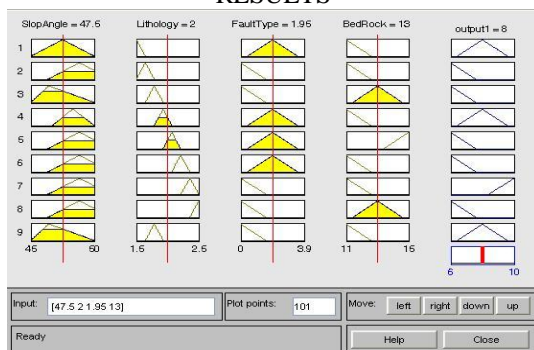

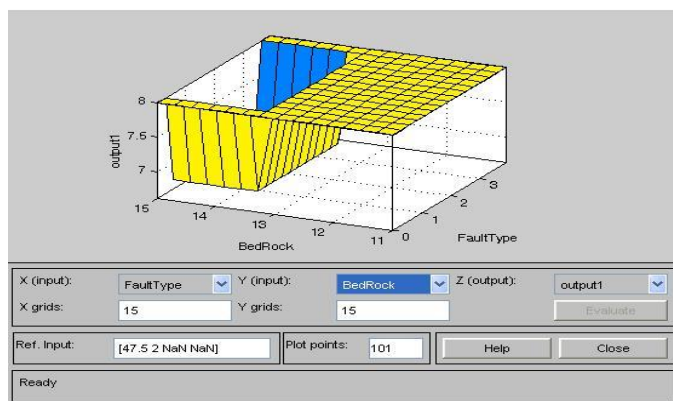
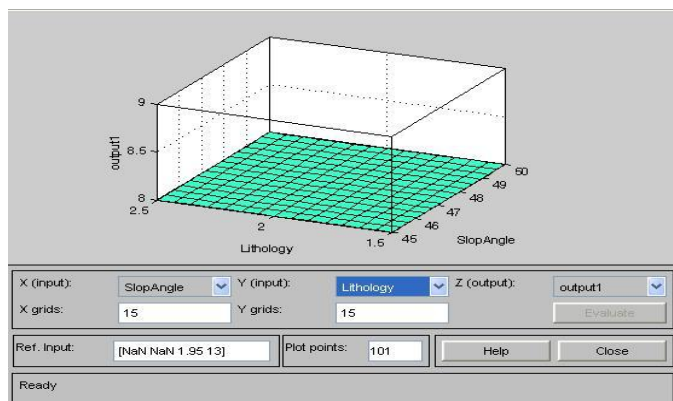

1. If (SlopAngle is SA1) and (Lithology is m1) and (FaultType is Moderate) and (BedRock is low) then (output1 is Rating2) (1) [7]
 2. If (SlopAngle is SA2) and (Lithology is m2) and (FaultType is High) and (BedRock is low) then (output1 is Rating1) (1)
 3. If (SlopAngle is SA3) and (Lithology is m3) and (FaultType is High) and (BedRock is Moderate) then (output1 is Rating1) (8)
 4. If (SlopAngle is SA4) and (Lithology is m4) and (FaultType is Moderate) and (BedRock is low) then (output1 is Rating2) (1)
 5. If (SlopAngle is SA2) and (Lithology is m5) and (FaultType is Moderate) and (BedRock is High) then (output1 is Rating1) (1)
 6. If (SlopAngle is SA2) and (Lithology is m6) and (FaultType is Moderate) and (BedRock is low) then (output1 is Rating1) (1) [9]
 7. If (SlopAngle is SA2) and (Lithology is m7) and (FaultType is High) and (BedRock is low) then (output1 is Rating3) (1)
 8. If (SlopAngle is SA2) and (Lithology is m8) and (FaultType is High) and (BedRock is Moderate) then (output1 is Rating1) (1)
 9. If (SlopAngle is SA3) and (Lithology is m3) and (FaultType is High) and (BedRock is low) then (output1 is Rating2) (1) [10]

CONCLUSION

The Proposed soft computing model shows a way to integrate different parameters of earthquake based landslides in a soft computing approach. The model proposes an integrated approach with field study data as well as remote sensing data to produce a whole sum picture of a landslide prone zone or region. The proposed model is also adaptable in nature. However it initially takes Darjeeling Himalaya as a region of study but it can be implemented in other landslide hazard susceptible zones. The approach is holistic and straight forward. It only requires various parameters as inputs. Evaluation of the model has also been included to show its nature of implementation. The approach here chosen to be fuzzy logic but further a Neuro-fuzzy approach might be considered. A further study and enhancement of the proposed model is still under development. We

expect that in future we will be able to provide an extensive universally adaptable soft computing model for landslide hazard zone mapping and risk analysis.

REFERENCES

- [1] Kishor Kumar, Rahul Devrani, Sudhir Mathur. Landslide Hazard Potential Analysis Using Gis, Patalganga Valley, Garhwal, Western Himalayan Region of India (European Journal of Scientific Research ISSN 1450-216X Vol.45 No.3 (2010), pp.346-366).
- [2] Saibal Ghosh, Niroj K Sarkar & Chinmoy Paul. GIS-based slope stability evaluation— case study from Paglajhora landslide complex, Darjeeling Himalaya, India (Engineering Geology Division Geological Survey of India Eastern Region Kolkata).
- [3] Donatella Caniani, Stefania Pascale, Francesco Sdao, Aurelia Sole. Neural networks and landslide susceptibility: a case study of the urban area of Potenza (Springer Science+Business Media B.V. 2007).
- [4] Saibal Ghosh. A Knowledge-guided quantitative prediction for landslide hazard and risk --- case study in Darjeeling Himalaya, India (Department of Earth System Analysis ITC, The Netherlands).
- [5] Hasan OZDEMIR, Huseyin TUROGLU. Landslide Susceptibility Assessment Using GIS and RS In the Havran River Basin (Balikesir-TURKEY) (Istanbul University, Geography Department, Ordu Cad. No: 196, 34459, Laleli, Istanbul-TURKEY).
- [6] S. Sarkar, D.P. Kanungo, A.K. Patra and Pushpendra Kumar. GIS Based Landslide Susceptibility Mapping — A Case Study in Indian Himalaya (by Universal -Academy Press, Inc. / Tokyo, Japan, 2006 PP-617-624).
- [7] S. Sarkar and D.P. Kanungo. An Integrated Approach for Landslide Susceptibility Mapping Using Remote Sensing and GIS (Photogrammetric Engineering & Remote Sensing Vol. 70, No. 5, May 2004, pp. 617–625.).
- [8] G.P. Ganapathy, K. Mahendran, S.K. Sekar. Need and Urgency of Landslide Risk Planning for Nilgiri District, Tamil Nadu State, India (INTERNATIONAL JOURNAL OF GEOMATICS AND GEOSCIENCES Volume 1, No 1, 2010).
- [9] P. AMIRDHA PRIYADHARSHINI, M. SUDHA, S. SANJEEVI AND S. JAYASEELAN. REMOTE SENSING AND GIS FOR LANDSLIDE VULNERABILITY STUDIES IN THE KODAIKANAL HILLS, SOUTH INDIA (Anna University, paper reference no: 106).
- [10] John Mathew, V. K. Jha and G. S. Rawat. Weights of evidence modelling for landslide hazard zonation mapping in part of Bhagirathi valley, Uttarakhand (CURRENT SCIENCE, VOL. 92, NO. 5, 10 MARCH 2007).
- [11] D. P. Kanungo, M. K. Arora, S. Sarkar and R. P. Gupta. Landslide Susceptibility Zonation (LSZ) Mapping - A Review (Journal of South Asia Disaster Studies Vol. 2 No. 1 June 2009).
- [12] S. Amin, R. Gupta, A.K. Saha, M.K. Arora & R.p. Gupta. GENETIC ALGORITHM BASED NEURAL NETWORK FOR LANDSLIDE HAZARD ZONATION: SOME PRELIMINARY RESULTS (National workshop on Application of Rock Engineering in Nation's Development (In Honour of Prof. Bhawani Singh) April 27-28, 2001, Roorkee.).
- [13] 13. Dr. P. Rajesh Prasanna, S. Evany Nithya. Data Mining Approach For Landslide Susceptibility Mapping For Kundhappallam Watershed, Nilgiris, Tamil Nadu (12th Esri India User Conference 2011).
- [14] 14. O.P. Mishra, M. Ghatak, D. Chamlagain. SAARC EXPERT GROUP MEETING ON LANDSLIDE TERMINOLOGY, CLASSIFICATION, DOCUMENTATION AND HAZARD MAPPING (Published by the SAARC Disaster Management Centre, New Delhi).

- [15] P. Flentje, D. Stirling, R. N. Chowdhury. Landslide Susceptibility and Hazard derived from a Landslide Inventory using Data Mining – an Australian case study (University of Wollongong).
- [16] Miloš Marjanović, Jan Čaha. Fuzzy approach to landslide susceptibility zonation (V. Šnigaj, J. Pokorný, K. Richta (Eds.): Dato 2011, pp. 181–195, ISBN 978-80-248-2391-1).
- [17] A. GEMITZI, G. FALALAKIS, P. ESKIOGLOU, C. PETALAS. EVALUATING LANDSLIDE SUSCEPTIBILITY USING ENVIRONMENTAL FACTORS, FUZZY MEMBERSHIP FUNCTIONS AND GIS (Global NEST Journal, Vol 13, No 1, pp 28-40, 2011).
- [18] P. K. DUNBAR, R. G. BILHAM, M. J. LAITURI. EARTHQUAKE LOSS ESTIMATION FOR INDIA BASED ON MACROECONOMIC INDICATORS
- [19] LESZEK STARKEL (KRAKÓW). AMBOOTIA LANDSLIDE VALLEY — EVOLUTION, RELAXATION, AND PREDICTION (DARJEELING HIMALAYA) (STUDIA GEOMORPHOLOGICA CARPATHO – BALCANICA Vol. XLIV, 2010: 113–133).
- [20] I Nengah Surati JAYA And Nobuyuki ABE. Methods for Detecting Landslides within Mountainous Area Using Multitemporal SPOT HRV Imagery: A Case Study in Niigata, Japan (Bull. Facul. Agric. Niigata Univ, 58(2):109-116, 2006).
- [21] Khalid Abdulla Shams. The effect of ridged vs flat cultivation at two slopes upon runoff, erosion, crop growth & yield (Department of Agronomy college of agriculture Andhra Pradesh Agricultural University Rajendranagar, Hyderabad (INDIA), 1977).
- [22] Ignazio M. Mancini, Salvatore Masi, Donatella Caniani and Donata S. Lioi. Department of Engineering and Physics of the Environment, University of Basilicata, Italy. Fuzzy Logic and Neuro-Fuzzy Networks for Environmental Hazard Assessment.